

NOTES:

1 APPLY LOCTITE QUICKSTIX 248 THREAD LOCKER, PER MANUFACTURER'S SPECIFICATIONS.

624	P/N : CW30951-101	SUBREV : F
DRAWN BY : MAH	DATE : 05.24.11	SHEET 1 OF 5

D

C

B

A

4

3

2

1

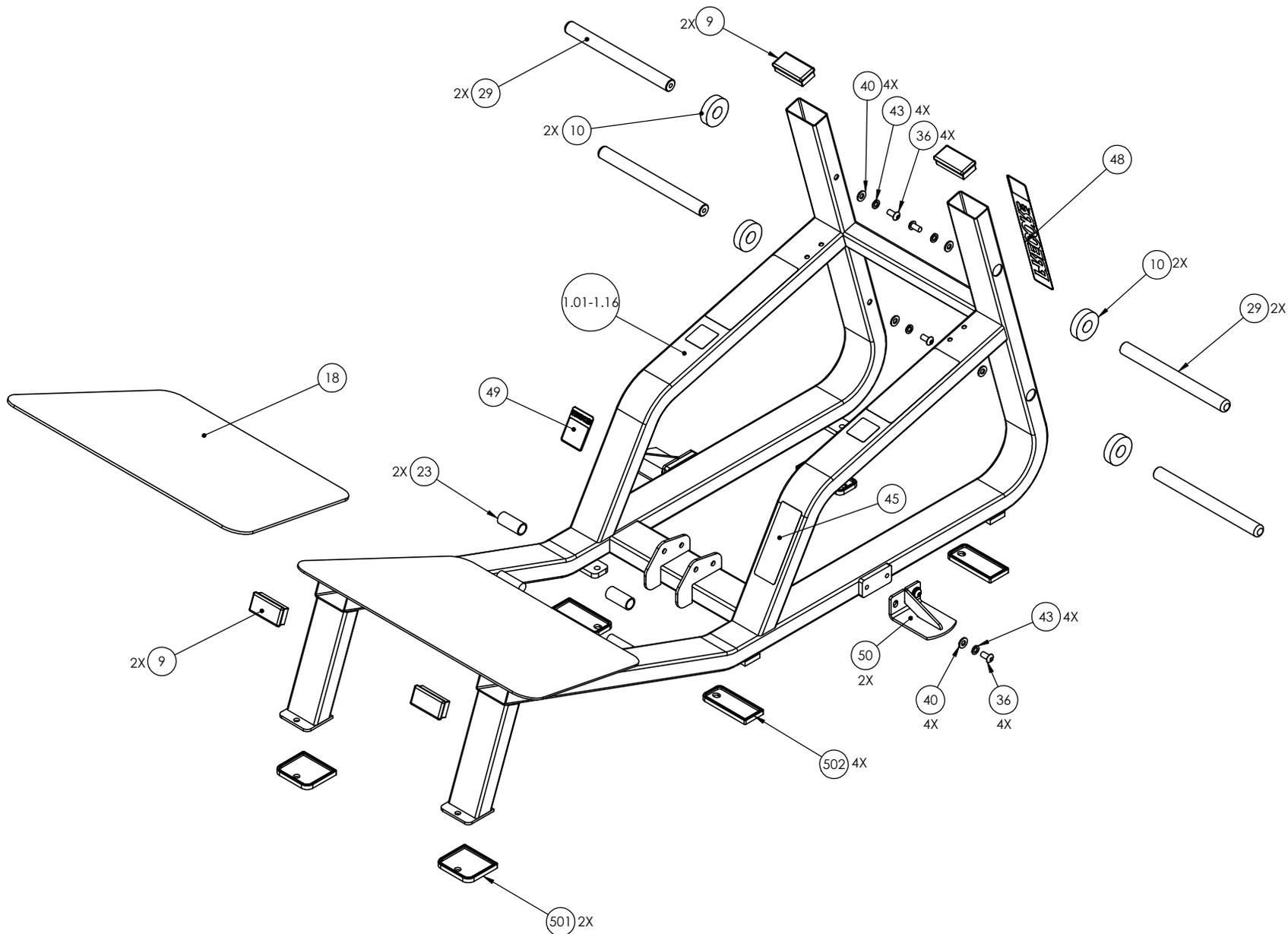

D

C

B

A

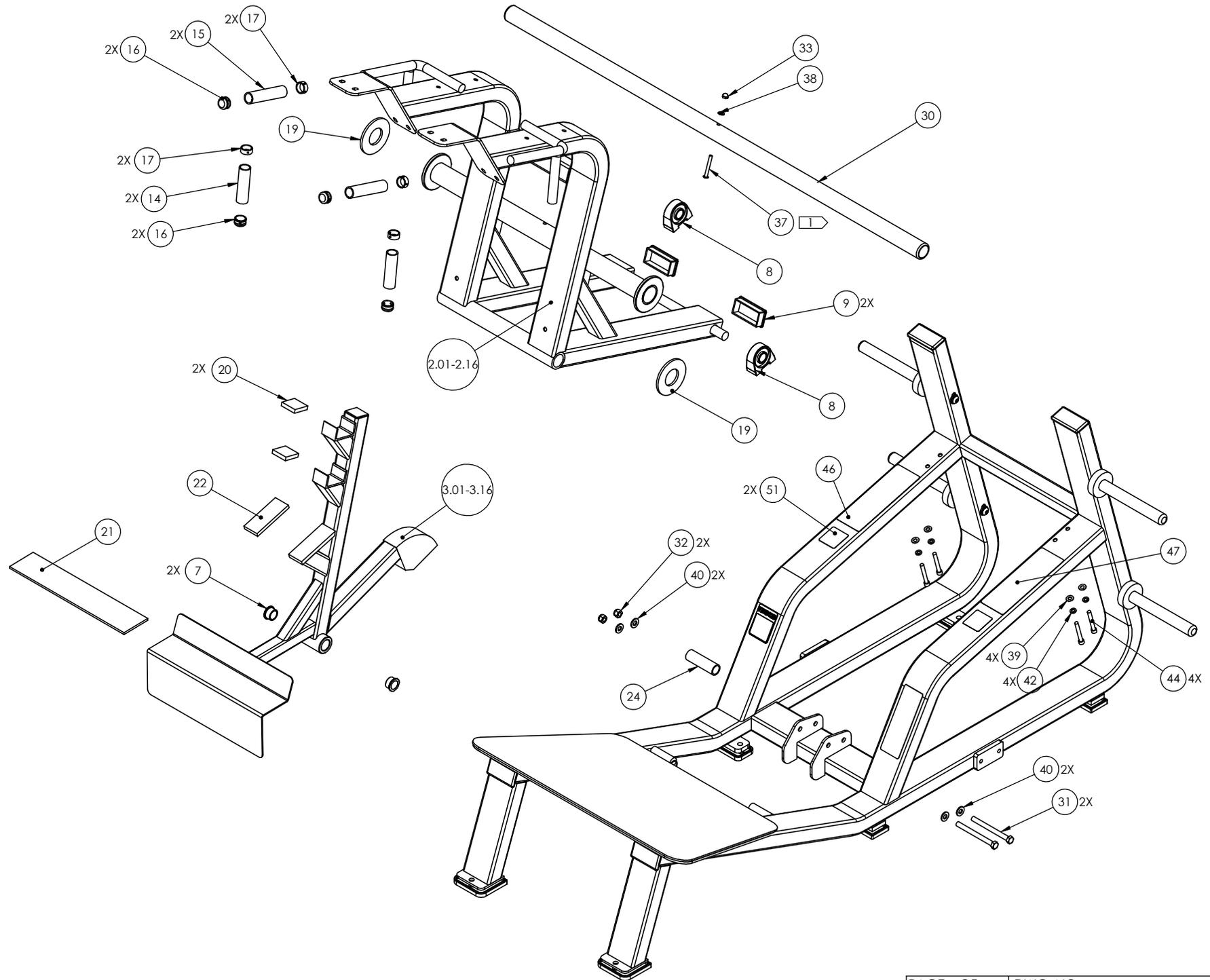

D

C

B

A

4

3

2

1

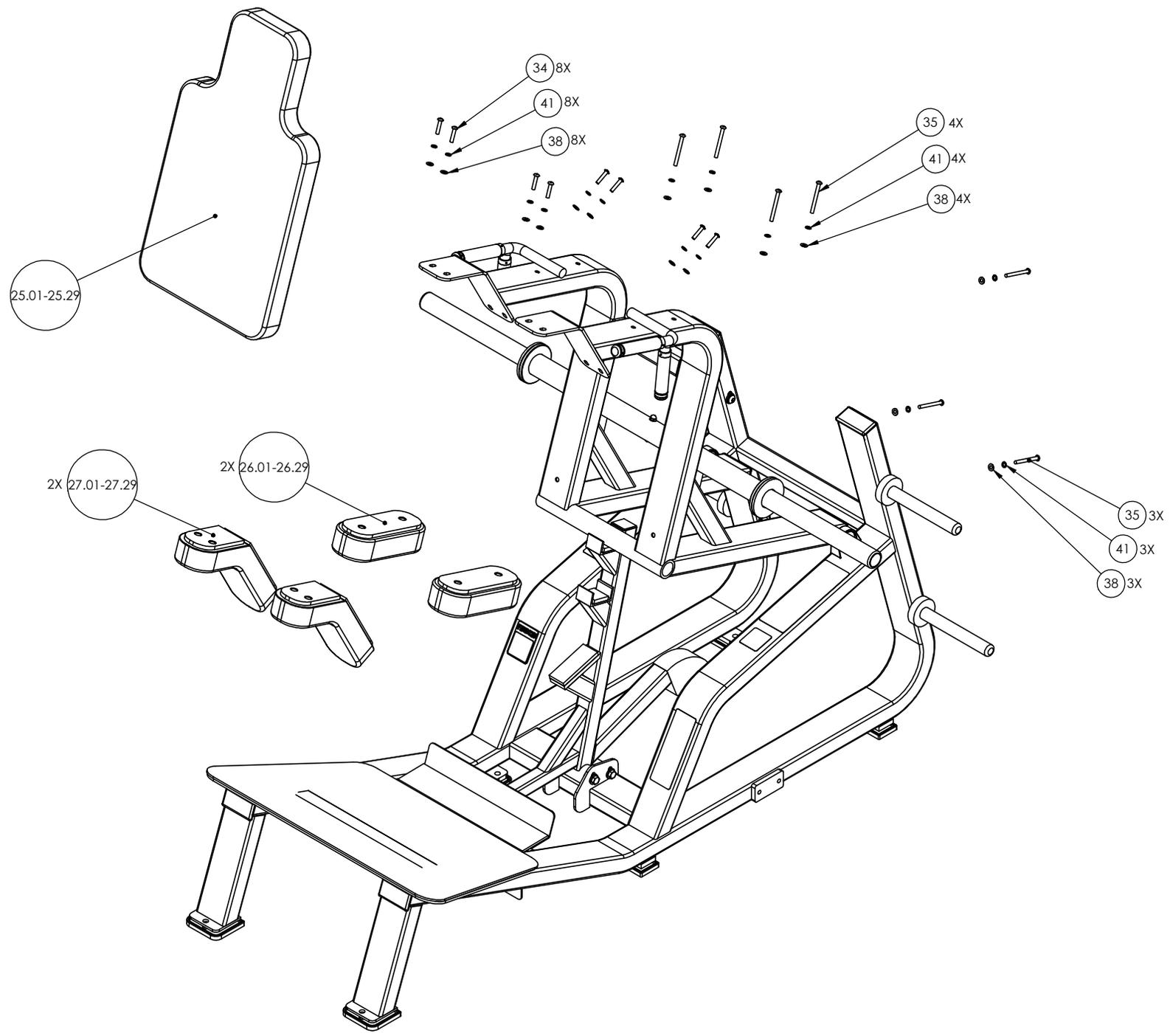

D

C

B

A

SOME ITEMS HAVE BEEN
OMITTED FOR CLARITY

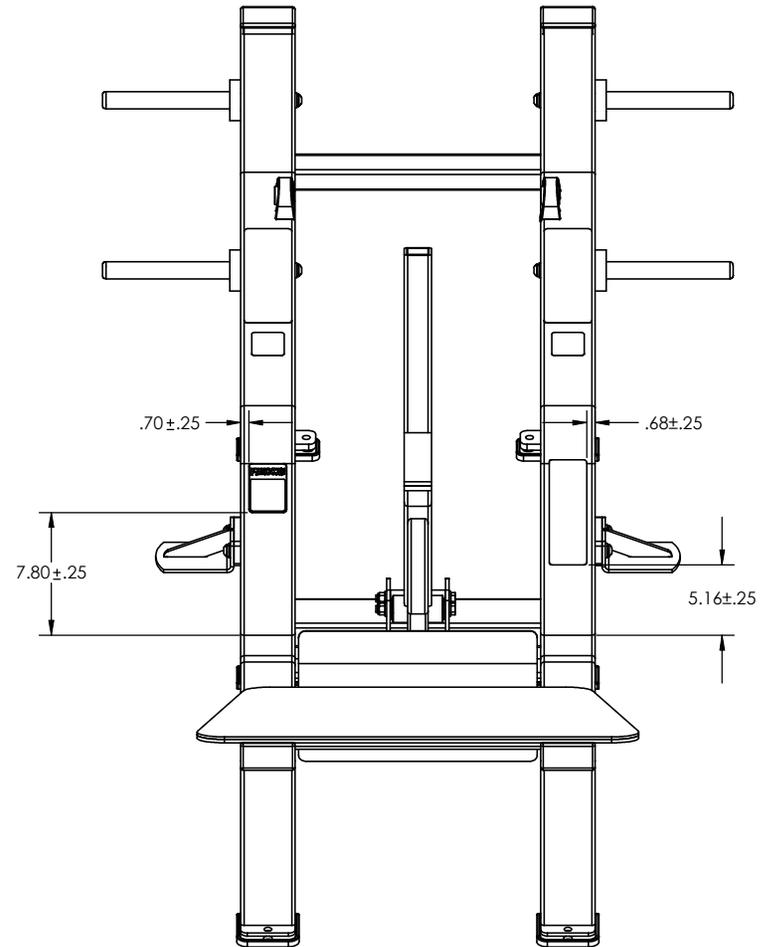
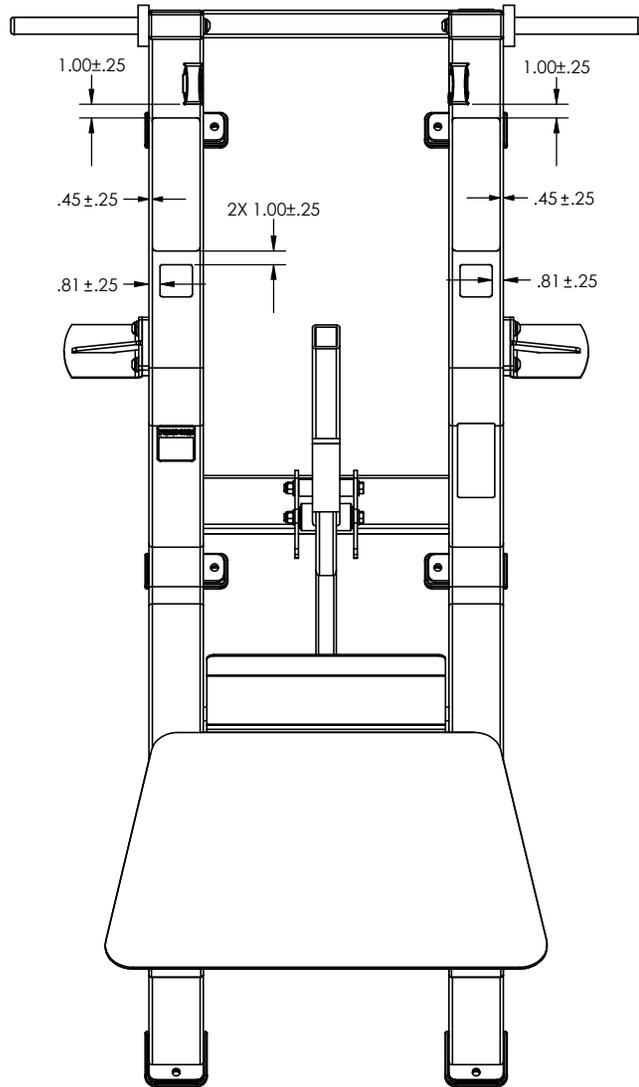

624 Super Squat

Part Number	Description	Bubble Number
CW624SA1-211	ASSY,624/FLT562 MAIN FRAME, SKY WHI	1.01
CW624SA1-311	ASSY,624/FLT562 MAIN FRAME, STONE H	1.11
CW624SA1-321	ASSY,624/FLT562 MAIN FRAME,TITANIUM	1.12
CW624SA2-211	ASSY, CARRIAGE, 624/FLT562,SKY WHIT	2.01
CW624SA2-311	ASSY, CARRIAGE, 624/FLT562,STONE HG	2.11
CW624SA2-321	ASSY, CARRIAGE, 624/FLT562,TITANIUM	2.12
CW624SA3-211	ASSY, FOOT PEDAL STOP, 624/FLT562,	3.01
CW624SA3-321	ASSY, FOOT PEDAL STOP, 624/FLT562,	3.12
CW30057-101	LABEL,INSTRUCTION,624 FACE IN	4
CW30058-101	LABEL,INSTRUCTION,624 FACE OUT	5
CW10043-134	BUSHING, BRONZE, 1" ID X 1 1/4" OD	7
CW12406-101	PILLOW BLOCK, BEARING, 2 BOLT	8
CW11311-102	ENDCAP, REC TUBE, 2X4, BLK PLASTIC	9
CW12402-102	BUMPER, ID 1.248 , BLK RUBBER	10
CW34822-101	LABEL, "ASSEMBLED IN THE USA"	11
CWAC1183-101	LABEL, WARNING, SERIOUS INJURY	13
CWGR4604-000	GRIP, RUBBER, 1.00" OD HANDLE, 4.00	14
CWGR4605-500	GRIP, RUBBER, 1.00" OD HANDLE, 5.50	15
CWAC218-901	HANDLE END CAP W/SET SCREWS, DIA 1"	16
CWAC219-902	HNDL RETAINER RNG, W/SS,1.040" I.D.	17
CW30505-103	CUT PIECE, CREPE, 1/4 THICK, 33.31	18
CWCP1002-102	CUT PIECE, CREPE, 1/4 THICK, 2.00 I	19
CW30014-203	CUT PIECE, CREPE, 3/8 THICK, 2.00 X	20
CW30013-206	CUT PIECE, CREPE, 1/4 THICK, 3.63 X	21
CWGR4602-750	GRIP, RUBBER, 1.00" OD HANDLE, 2.75	23
CWGR4604-000	GRIP, RUBBER, 1.00" OD HANDLE, 4.00	24
CWPD1309D-101	PAD,9X17.5X31.5,3HL,W/PLATE,BLACK	25.01
CWPD1310B-101	PAD,4.5X10-9/16,2HOLES,W/BP,BLACK	26.01
CWPD1311J-101	PD,ANG,2P(4.5X10.13)(4.5X6.75)BLK,W	27.01
CWPF3441-741	BAR, STEEL, RND, CLR ZN	28
CWPF1468-741	BAR,STEEL RND, DIA 1 1/4" X (14), 1	29
CWSA1098-741	ASSY, WEIGHT HOLDER, 63 1/4",CLR ZI	30
CWHADYN050-550	SCREW, HEX,BLK, 1/2-13 X 5 1/2 FUL	31
CWKDYN050-059	LOCKNUT, NYLON INSERT, FULL, UNC, 1	32
CWKADLN031-053	NUT, ACORN, 5/16-18	33
CWTAYN031-150	SCREW, BUTTON HEAD, BLK XYLAN, 5/16	34
CWTAYN031-325	SCREW, BUTTON HEAD, BLK XYLAN, 5/16	35
CWEANN016-013	SCREW, SET, SCKT, CUP POINT, 8-32 X	36
CWTAYN050-100	SCREW, BUTTON HEAD, BLK XYLAN, 1/2	36
CWTAYN031-250	SCREW, BUTTON HEAD, BLK XYLAN, 5/1	37
CWWBKN031-007	WASHER, FLAT, TYPE A, SAE, 5/16 ID	38
CWWBKN038-007	WASHER, FLAT, TYPE A, SAE, 3/8 ID	39
CWWBKN050-010	WASHER, FLAT, TYPE A, SAE, 1/2 ID X	40
CWWALYN031-008	WASHER, SPLIT, 5/16 ID, BL	41
CWWALYN038-009	WASHER, SPLIT, 3/8 ID, BLK XYLAN	42
CWWALYN050-013	WASHER, SPLIT, 1/2 ID, BLK XYLAN	43
CWCAYN038-275	SCREW, SOCKET HEAD, BLK XYLAN, 3/8	44
CW30010-102	LABEL,WARNING STRENGTH	45

CW30057-101	LABEL,INSTRUCTION,624 FACE IN	46
CW30058-101	LABEL,INSTRUCTION,624 FACE OUT	47
CW31756-101	LABEL, PRECOR USA ICARIAN LINE	48
CW31759-101	LABEL, SMALL PRECOR USA ICARIAN LIN	49
CW33286-731	WELDMENT, STABILITY FOOT,BLACK ZINC	50
CW35144-101	LABEL, MAX LOAD, PLATE-LOADED STREN	51
CWAC1177-101	FLOOR PROTECTOR, RUBBER, 4.563 X 4.	501
CWAC1178-101	FLOOR PROTECTOR, RUBBER, 2.563 X 6.	502